

1.0	machine connection: Drain line hose fitted as odour trap in interior of machine	DN 22
1.1	drain (recommended height 70 mm, over 120 mm waste water pump required)	DN 50
2.0	machine connection: fresh water line	G 3/4"
2.2	soft cold water 10°C max. 0,54 mmol/l CaCO ₃ / 53,4 ppm/CaCO ₃ (max.3°GH) approx. water flow rate 0,3 l/s min. flow pressure: 250 kPa / 2,5 bar upstream of the solenoid valve, maximum pressure: 500 kPa / 5 bar stopcock and fine screen ≤ 25 μm	DN 20
		G 3/4 a
3.0	machine connection: electricity connecting cable	5G 2,5mm ²
3.1	electricity supply to the machine	3N PE 400V ~ 50Hz
	nominal current / - capacity	12.8 A 5.2 kW
	⚡ Voltage equalising cable	Fuse protection: 16 A
	Electrical equipment suitable for supply voltage: 3N PE 380-415 V 50 Hz / 1N PE 220-240 V 50 Hz	
heat load of the wash room		total ca.1.6 kW
in case of 15 program cycles /h		perceptible ca.1.0 kW
		latent ca.0.6 kW
all cables, pipes etc leaving machine		1,6 m
the position of the connection piping can also be mirror-inverted		
Machine Equipment		
(A) Entry height		
Potential free terminals (changeable to 230V) for local dosingsystem		

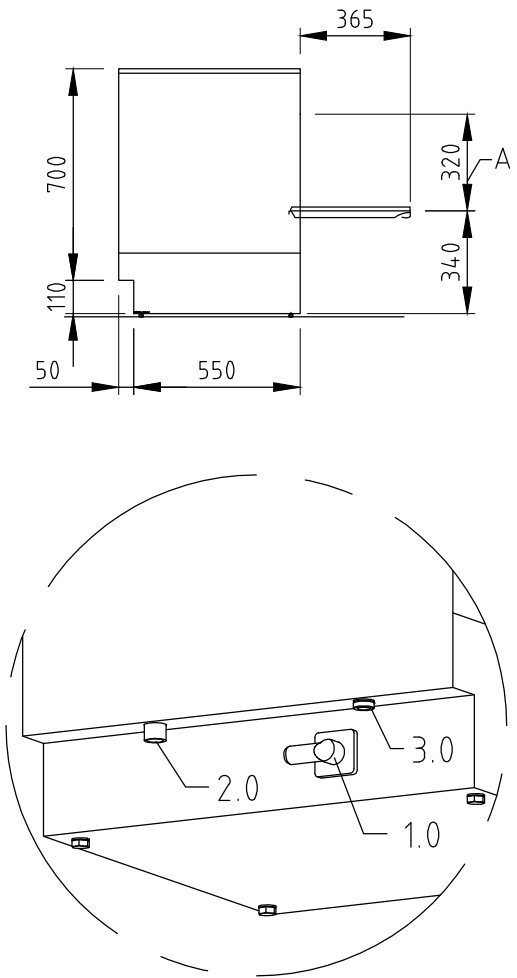
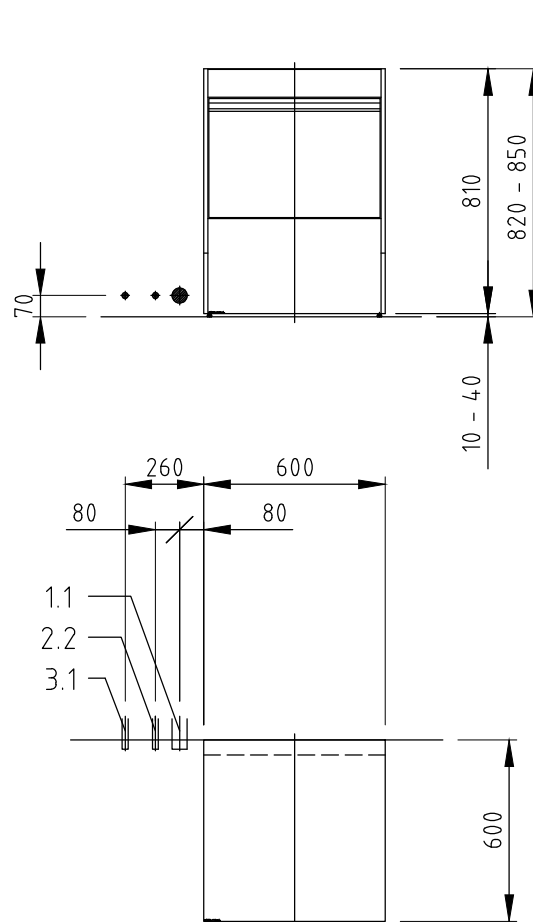

MP000427704.1.6

© COPYRIGHT by MEIKO

	MEIKO Wash-Up Technologies LTD. NO.2, Jingye Road Torch High Tech Industrial Development Zone Zhongshan, Guangdong,P.R.C, Postal code: 528437 Tel: +86 (0)760 85317591 Fax: +86 (0)760 85314217 Website: http://www.meiko.de http://www.meikochina.com		Revision	
	This drawing may not be neither passed to third parties for their information or copied or used for competitive purposes without our consent. All rights reserved. We reserve the right to make changes resulting from technical progress. This drawing was computer generated and is not subject to the checking and any release process; it is also not subject to change management. <u>Please note:</u> This document is only valid in conjunction with the conditions defined in Supplementary Sheet "Important Information". These can be requested from the manufacturer or downloaded from the Partnernet.		Reference	Type
		DISHWASHER STANDARD DRAWING / CHN	UPSTER U 500	
		GLASSES / CROCKERY	Drawing-No.	Order-No.
		S00085539		
Scale	drawn:	checked:		
1:25	24.07.2020 m-iplan	24.07.2020 m-iplan		

CHN

EN

© COPYRIGHT by MEIKO